

CLEUSON - DIXENCE

INTRODUCING AN HYDROELECTRIC COMPLEX
UNIQUE IN THE WORLD

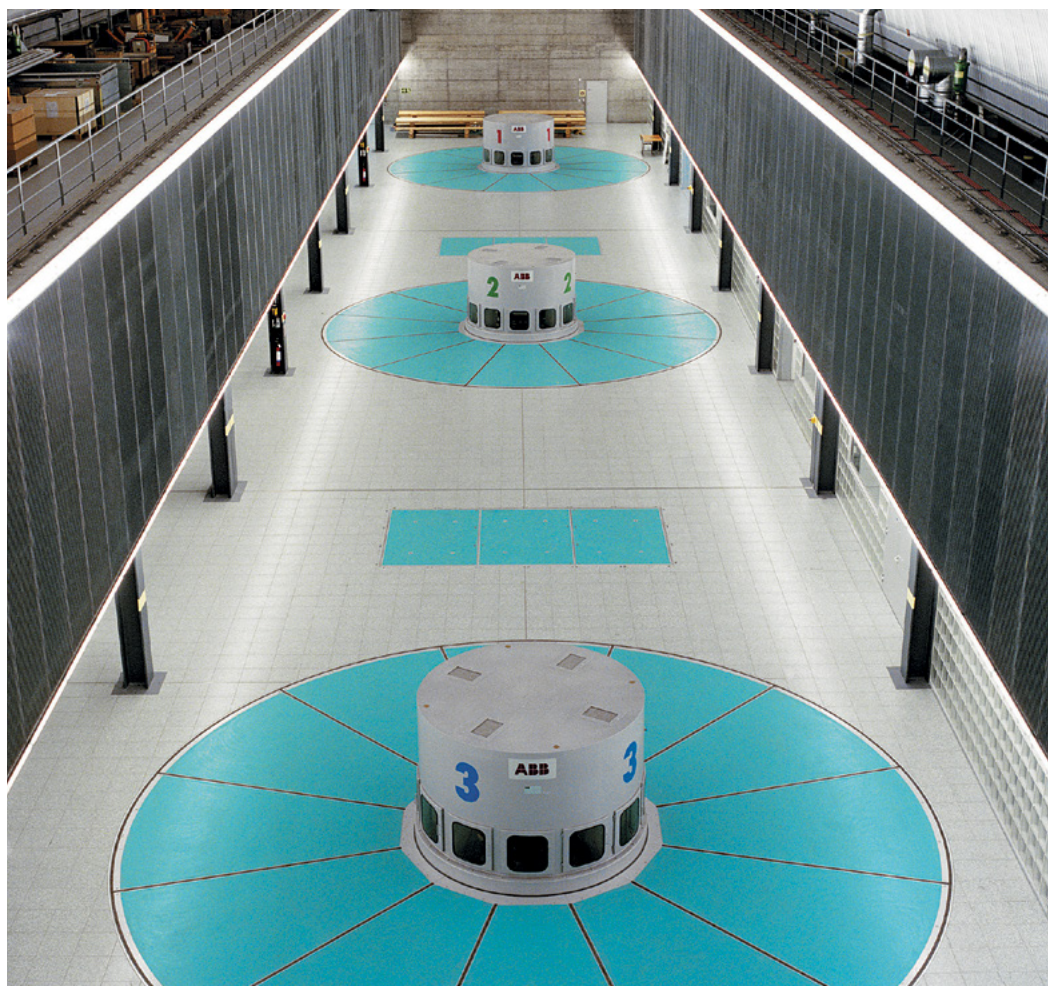

ALPIQ



CLEUSON-DIXENCE COMPLEX

CONTEXT



The original two power plants at Fionnay and Nendaz, with a capacity of 800 MW, take 2000 hours to turbine the 400 million m³ of water stored in the Grande Dixence lake.

To optimise this tremendous potential which represents 20% of the stored energy in Switzerland, the Cleuson-Dixence facility was built to increase the production capacity by 1200 MW to 2000 MW.

This reduces production to approximately 1'000 hours and, when there is a high demand for energy, enables peak power to be provided to the distribution grid.

Cleuson-Dixence produces 2.5 times the power of the Alpiq-Grande Dixence complex.

In 1992, a partnership was founded to build and operate this new facility which cost 1.3 billion CHF. Alpiq Suisse SA has a 7/22 participation and Grande Dixence SA a 15/22 participation.

CLEUSON-DIXENCE COMPLEX

OVERVIEW

- EXISTING FACILITIES
- CLEUSON-DIXENCE FACILITY
- TEMPORARY CONSTRUCTION CABLE CAR
- PRODUCTION PLANTS
- DAMS
- NON-OPERATING POWER PLANT

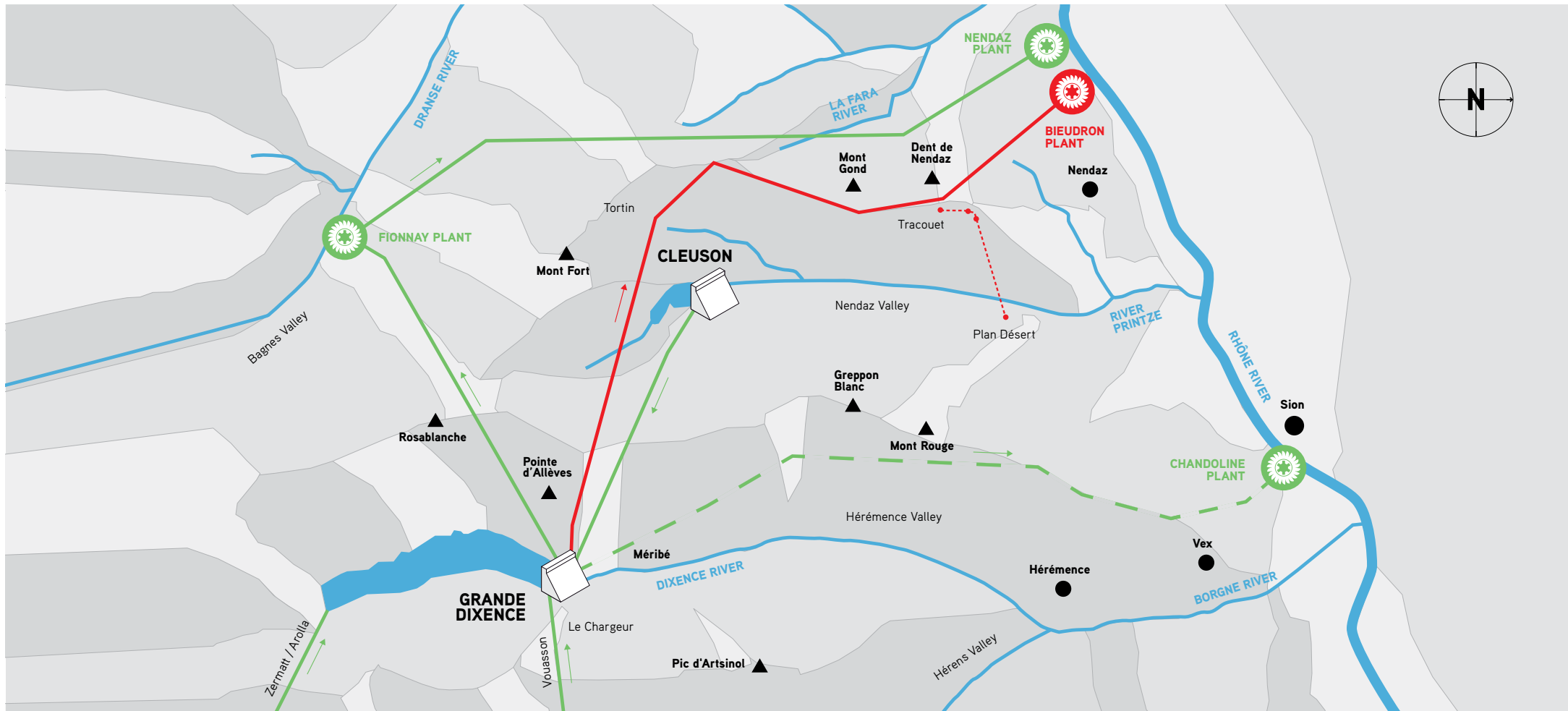

CLEUSON-DIXENCE COMPLEX

MAIN SPECIFICATIONS



Constructed entirely underground between 1993 and 1998, the Cleuson-Dixence facility includes the following main components:

- 1** A new water intake drilled through the Grande Dixence dam at Le Chargeur.
- 2** A 15.8 km long headrace tunnel from the dam to Tracouet.
- 3** A surge chamber at Tracouet, excavated in the Dent-de-Nendaz mountainside.
- 4** A 4.3 km long penstock connecting Tracouet to the Bieudron plant.
- 5** An underground plant equipped with three vertical generators each fitted with a 423 MW Pelton turbine and a 465 MVA generator.

(By way of comparison, the Gösgen nuclear power plant has an installed power capacity of 970 MW and the Leibstadt plant, 1165 MW).

The energy produced across all the Alpiq-Grande Dixence- Cleuson-Dixence facilities reaches approximately 2 billion kWh per year, which corresponds to the average annual consumption of 500'000 households.



CLEUSON-DIXENCE COMPLEX

LONGITUDINAL PROFILE DIAGRAM

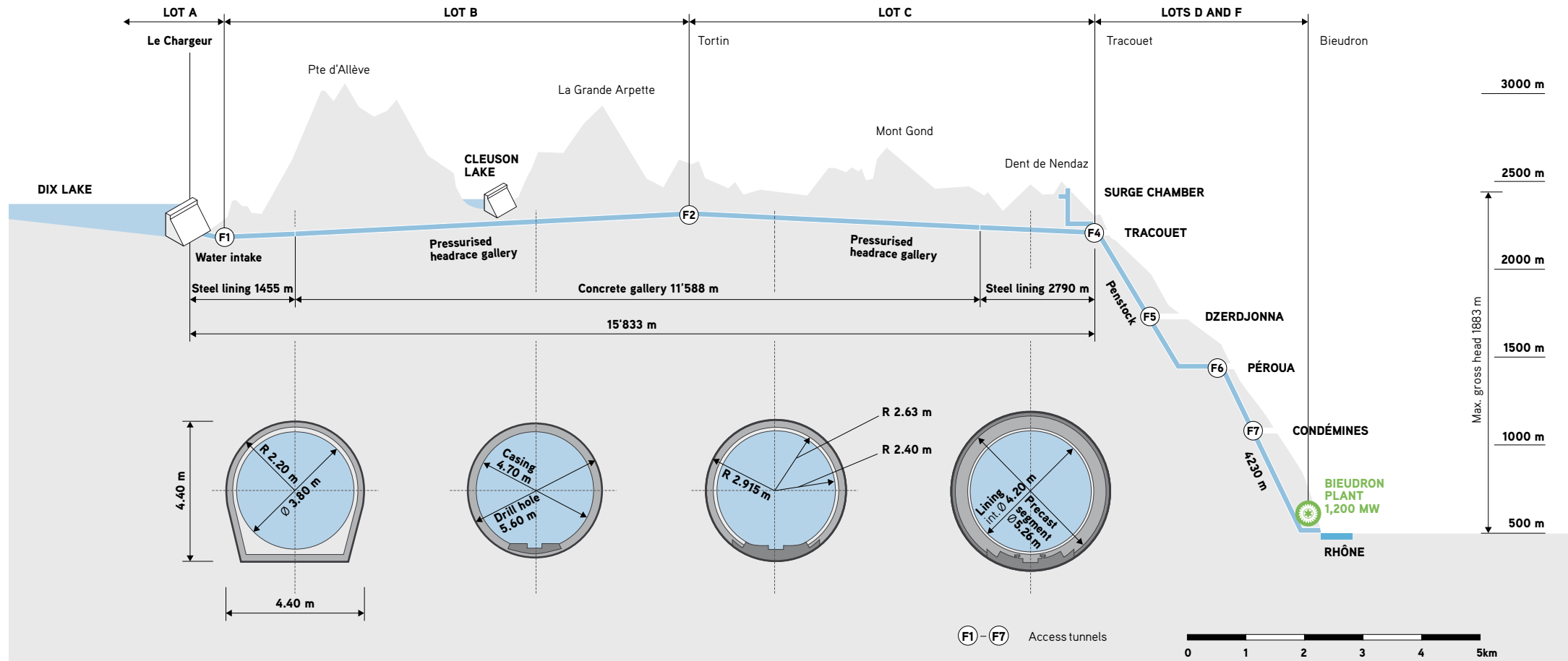

CLEUSON-DIXENCE COMPLEX

LONGITUDINAL PROFILE AND GEOLOGY (CROSS SECTIONS)

WATER INTAKE AT LE CHARGEUR (CROSS SECTIONS)

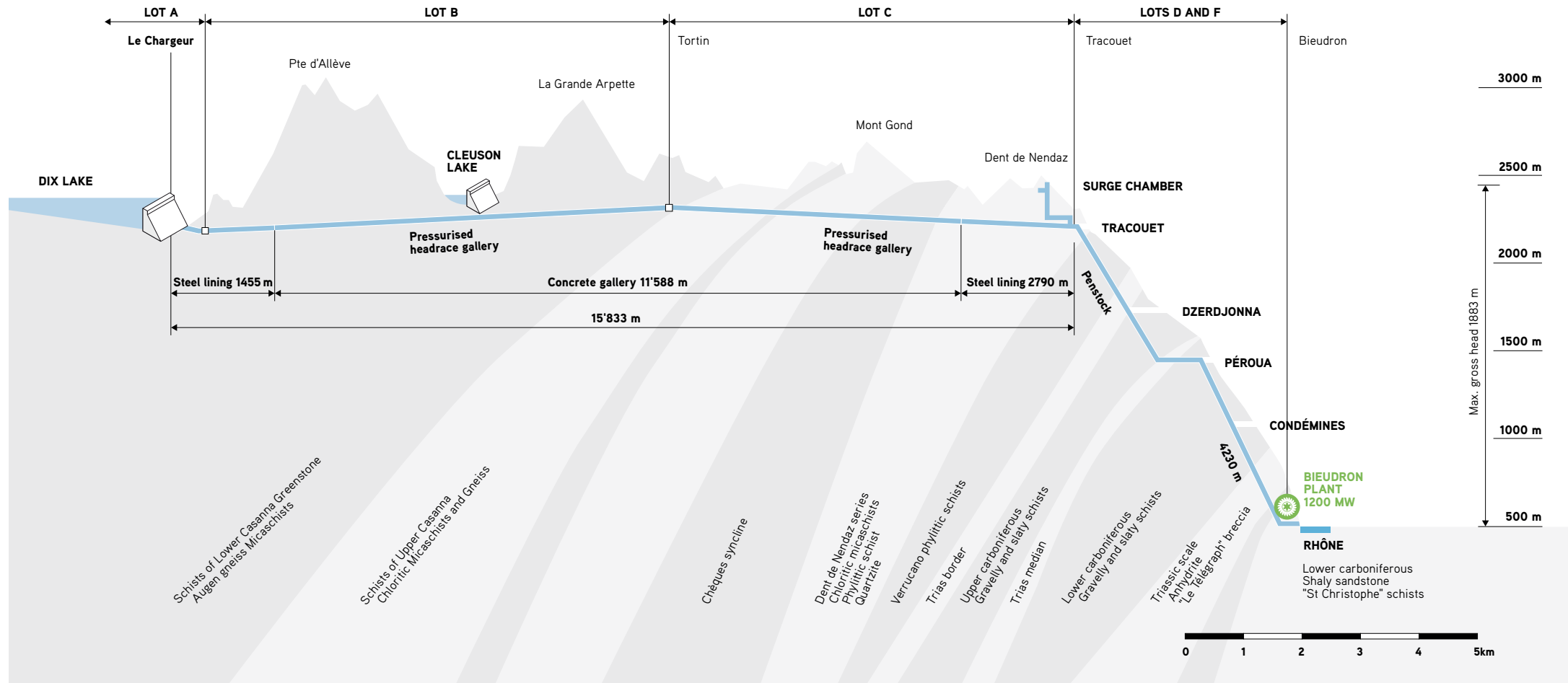
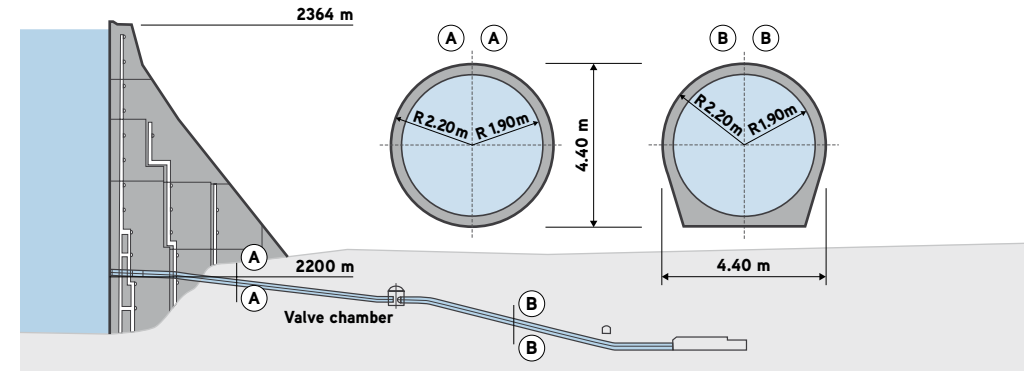

CLEUSON-DIXENCE COMPLEX

WATER INTAKE AT LE CHARGEUR (PLAN VIEW)

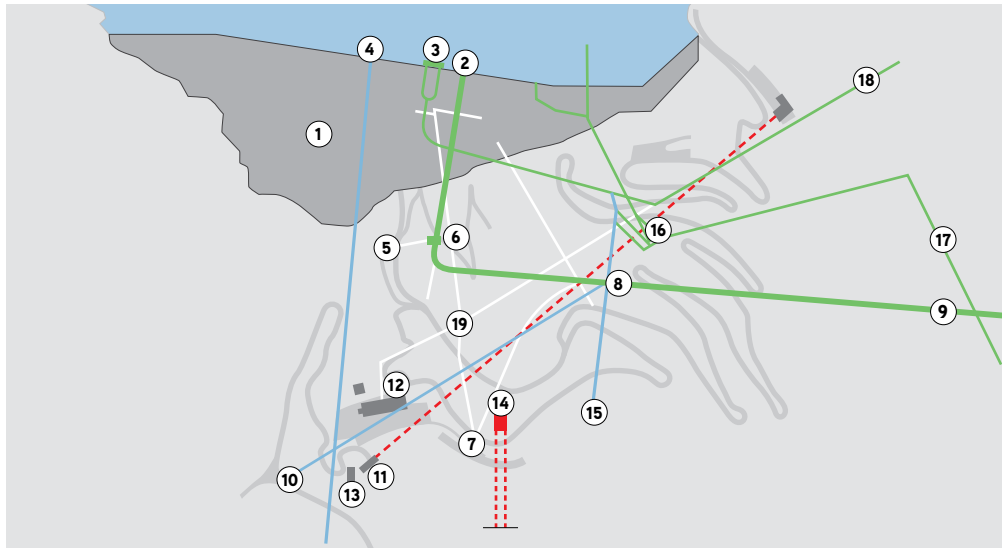

- | | |
|---|--|
| <ul style="list-style-type: none"> 1 GRANDE DIXENCE DAM, HEIGHT 285 m 2 NEW WATER INTAKE, 4.40 m DIA., $Q = 75 \text{ m}^3/\text{s}$ 3 GRANDE DIXENCE WATER INTAKE, 3.30 m DIA., $Q = 45 \text{ m}^3/\text{s}$ 4 WATER INTAKE FOR LOW BOTTOM-OUTLET 5 ACCESS TUNNEL TO THE NEW VALVE CHAMBER 6 NEW VALVE CHAMBER 7 ACCESS TUNNEL TO THE NEW HEADRACE TUNNEL 8 HEADRACE TUNNEL LOW POINT 9 HEADRACE TUNNEL BETWEEN LE CHARGEUR AND TRACOUET, LENGTH 15'833 km 10 WASTE WATER GALLERY FOR THE HEADRACE TUNNEL | <ul style="list-style-type: none"> 11 LOWER STATION FOR TOURIST CABLE CAR 12 « THE RITZ » HOTEL 13 EXHIBITION HALL 14 UPPER STATION FOR TEMPORARY CONSTRUCTION CABLE CAR (2 X 15 TONS) 15 MAIN DISCHARGE $Q = 50 \text{ M}^3/\text{S}$ 16 PRESSURE REGULATION SHAFT AND CLEUSON WATER INTRODUCTION 17 HEADRACE TUNNEL FOR THE CHANDOLINE PLANT $Q = 10.5 \text{ m}^3/\text{s}$ 18 HEADRACE TUNNEL FOR THE FIONNAY PLANT $Q = 45 \text{ m}^3/\text{s}$ 19 ACCESS TUNNEL TO PRESSURE REGULATION SYSTEMS AND VALVES |
|---|--|

BUTTERFLY VALVE CHAMBERS

- | | |
|---|--|
| <ul style="list-style-type: none"> 1 32 TONS OVERHEAD CRANE 2 WALKWAY 3 BY-PASS 4 COUNTERWEIGHT 5 VALVE BODY, 3.30 m DIA. 6 SERVOENGINE 7 UPSTREAM PIPE, 3.30 m DIA. | <ul style="list-style-type: none"> 8 REMOVABLE PIPE, 3.30 m DIA. 9 MANHOLE, 600 mm DIA. 10 VENT, 700 mm DIA. 11 BASES 12 INSPECTION WINCH 13 HEADRACE GALLERY 14 PENSTOCK INLET |
|---|--|

CHARGEUR

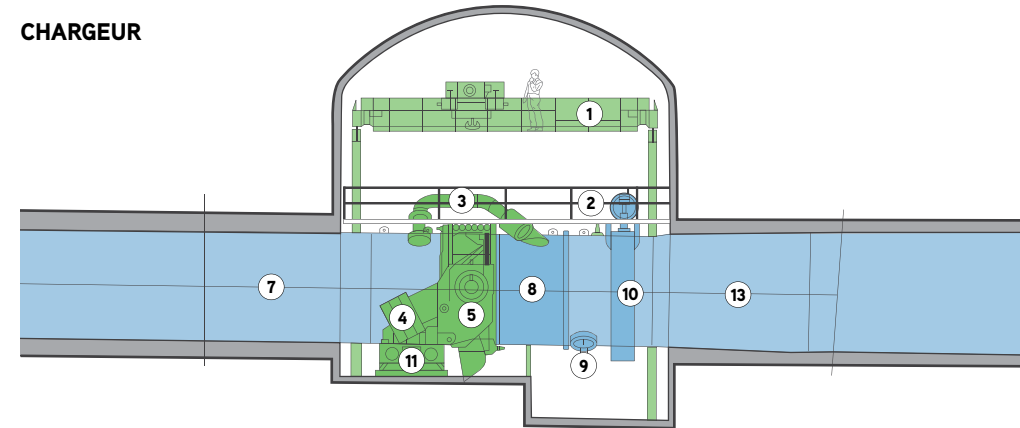

TRACOUET

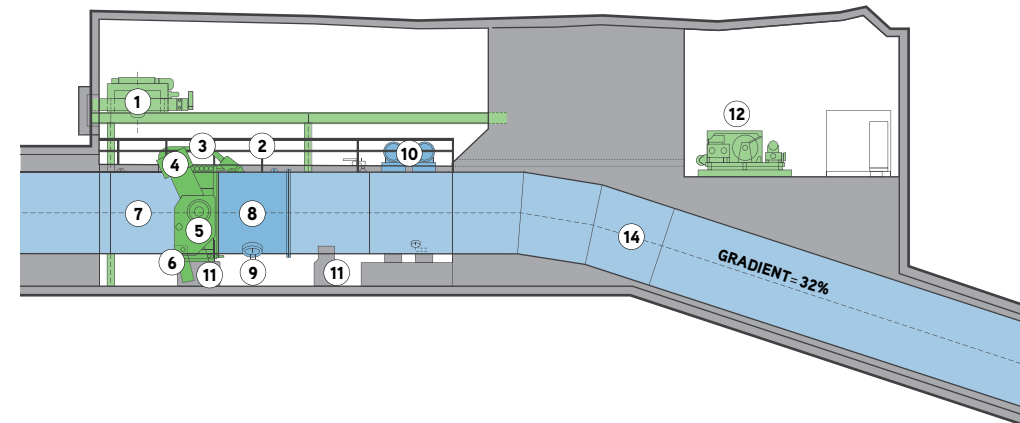

CLEUSON-DIXENCE COMPLEX

SURGE CHAMBER

LONGITUDINAL CROSS SECTION

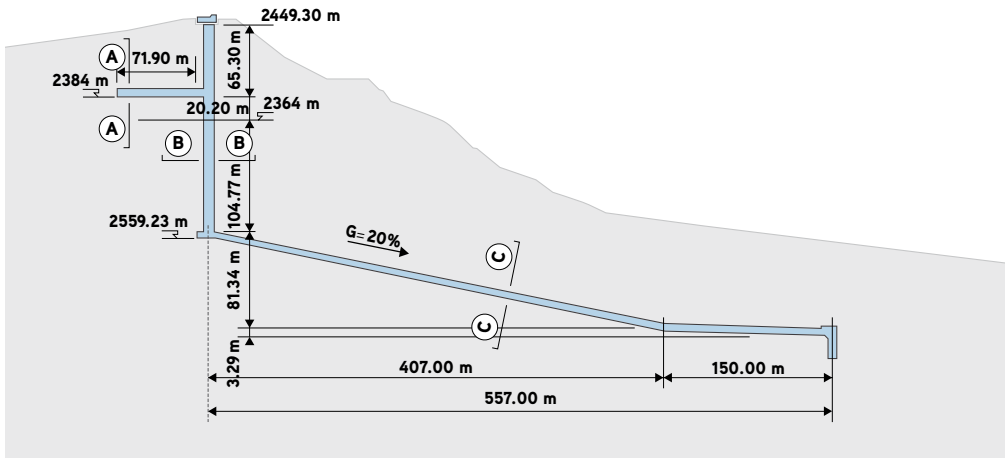

PLAN VIEW

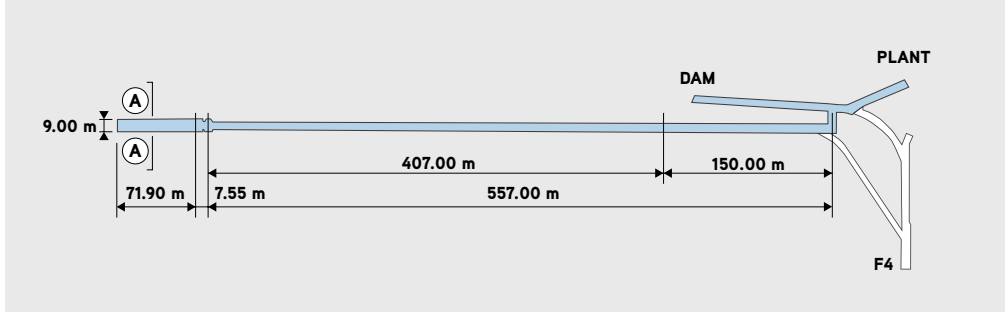

ACCESS TUNNEL TO TORTIN F2

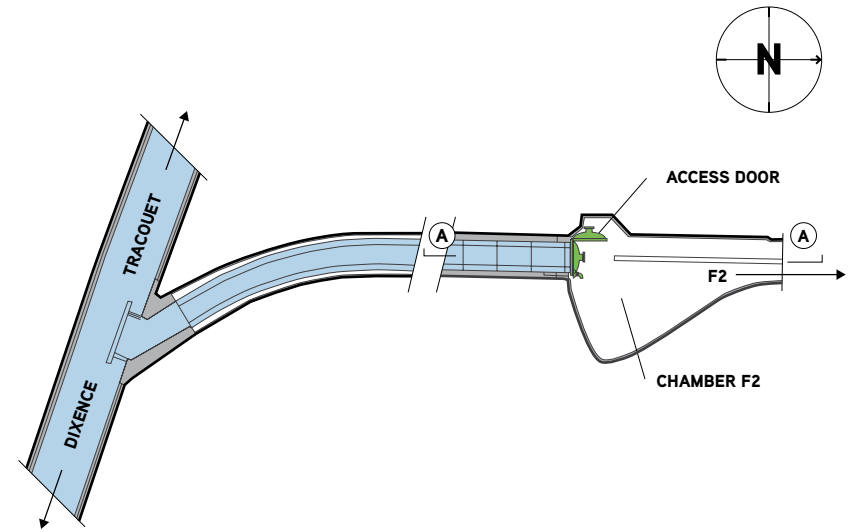

CROSS SECTION A-A

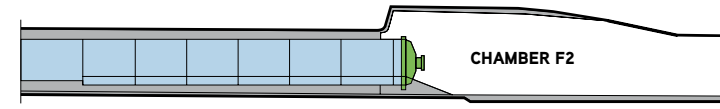

CROSS SECTION A-A

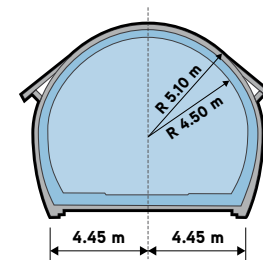

CROSS SECTION B-B

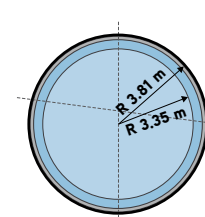

CROSS SECTION C-C

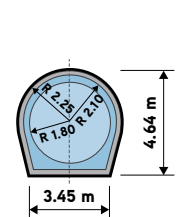



BIEUDRON POWER PLANT



Situated close to the Nendaz (Grande Dixence) power plant, the main cavern at Bieudron is over 100 m long, 39 m high and 25 m wide. The plant includes 3 caverns and several connecting tunnels and access tunnels representing an excavated volume of 150'000 m³.

It comprises 3 vertical generators operating at 428 rpm, with:

- 3 spherical valves with a diameter of 1.40 m
- 3 Pelton turbines with a unit power of 423 MW
- 3 x 465 MVA generators with water-cooled rotor windings and stator bars
- 3 x 465 MVA three-phase transformers
- 9 x 230/410 kV one-phase cables supplying power to the 410/230 kV station at Chamoson

The Bieudron power plant alone holds three world records, for : the drop height, the output of the Pelton turbines and the output per generator pole.

BIEUDRON POWER PLANT

PLAN OF LOCATION

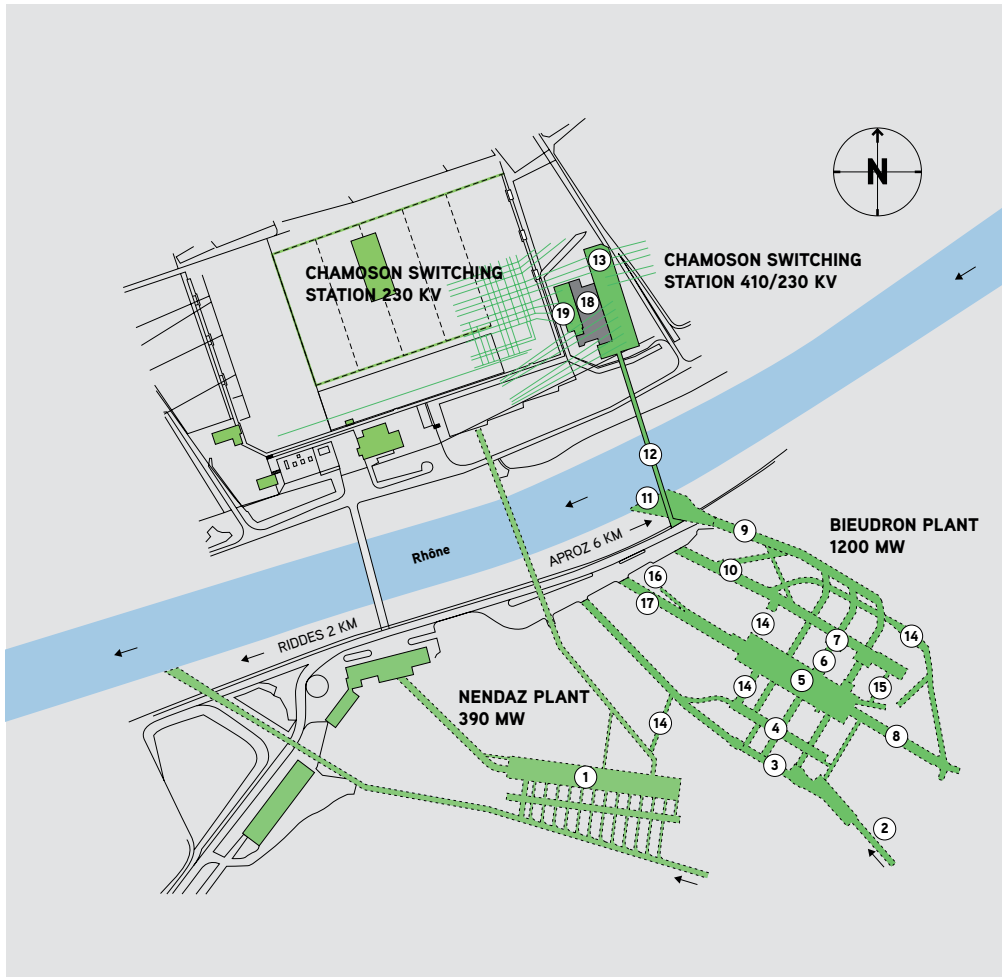

- 1 NENDAZ PLANT, 390 MW
- 2 PENSTOCK INLET, 75 m³/s
- 3 DISTRIBUTOR, 3 x 25 m³/s
- 4 SPHERICAL VALVES CHAMBER
- 5 BIEUDRON MACHINES ROOM
- 6 BAR TUNNELS
- 7 TRANSFORMER CELLS
- 8 COOLING WATER RESERVOIR, CAPACITY 21,000 m³
- 9 TAILRACE TUNNEL
- 10 410 kV CABLES TUNNEL AND ACCESS TO TRANSFORMERS
- 11 RESTITUTION WORK TO THE RIVER RHÔNE
- 12 CABLE GATEWAY
- 13 CHAMOSON SWITCHING STATION (410/230 kV)
- 14 CONNECTING TUNNELS
- 15 EMERGENCY TUNNEL
- 16 VENTILATION TUNNELS
- 17 ACCESS TUNNELS
- 18 COMMAND AND CONTROL SYSTEM FOR SWITCHING STATION
- 19 AUTO-TRANSFORMER (600 MVA/230/410 kV)

BIEUDRON POWER PLANT

OVERVIEW

- 1 PENSTOCK
- 2 DISTRIBUTOR
- 3 UNIT BRANCH (25 m³/s, PRESSURE 190 BAR)
- 4 VALVES CHAMBER
- 5 SPHERICAL VALVE (210 TONS PER UNIT)
- 6 MAIN CAVERN
- 7 423 MW PELTON TURBINE
- 8 465 MVA GENERATOR
- 9 CONTROL ROOM
- 10 250 TONS OVERHEAD CRANE
- 11 BUSBAR TUNNELS
- 12 21 kV 15'000 A BUSBARS
- 13 TRANSFORMER CELL
- 14 465 MVA THREE-PHASE TRANSFORMERS
- 15 230/410 kV ONE-PHASE CABLE OUTLET
- 16 TAILWATER BRANCH
- 17 MAINTENANCE AND STORAGE BUILDING
- 18 COOLING WATER RESERVOIR
- 19 16/0.4 kV AUXILIARY TRANSFORMERS
- 20 230/400 V SWITCHBOARDS
- 21 EMERGENCY TUNNEL
- 22 ASSEMBLY SITE
- 23 CONNECTING TUNNELS
- 24 ACCESS TUNNEL TO PLANT
- 25 ACCESS TUNNEL TO DISTRIBUTOR
- 26 TUNNEL FOR 410 kV CABLES AND ACCESS TO TRANSFORMERS
- 27 VENTILATION TUNNEL

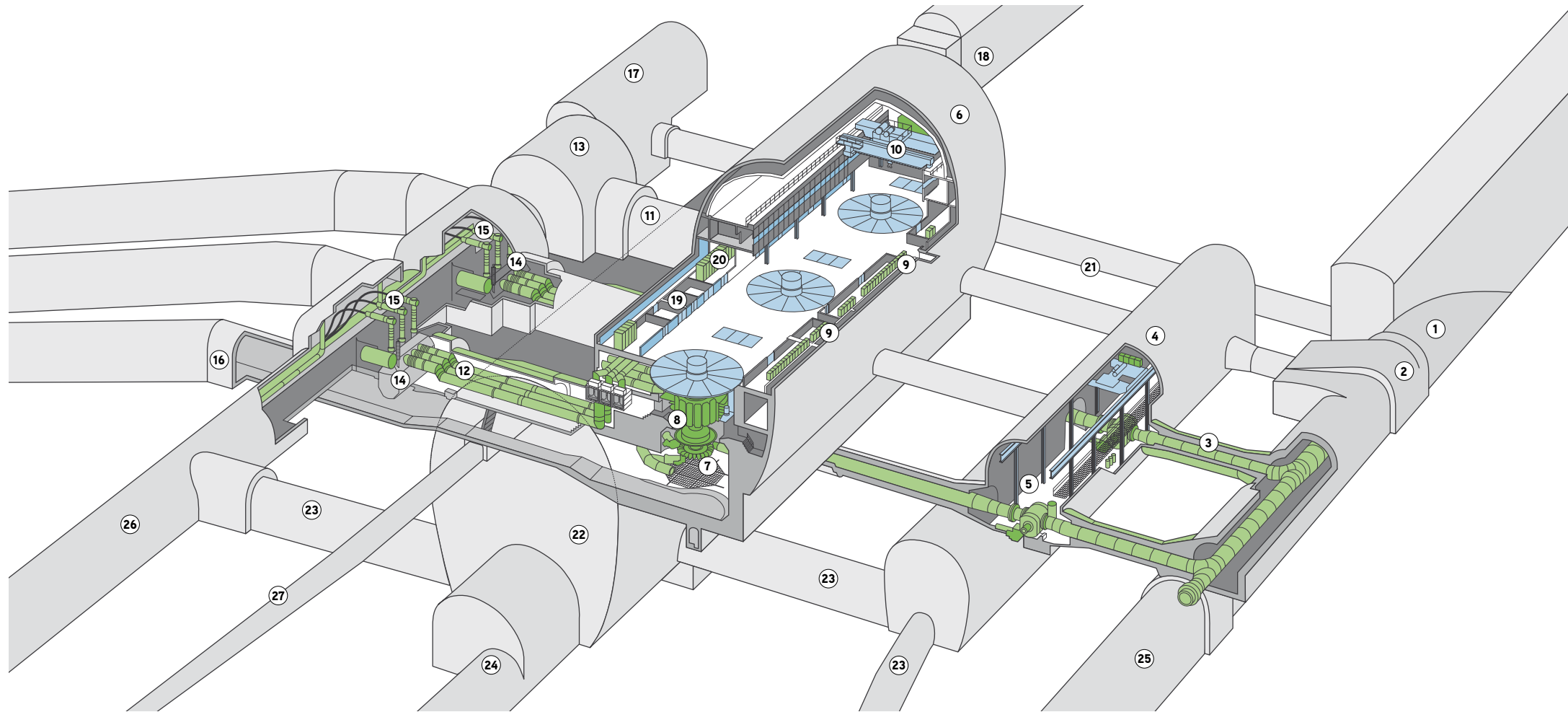

BIEUDRON POWER PLANT

SPHERICAL VALVE

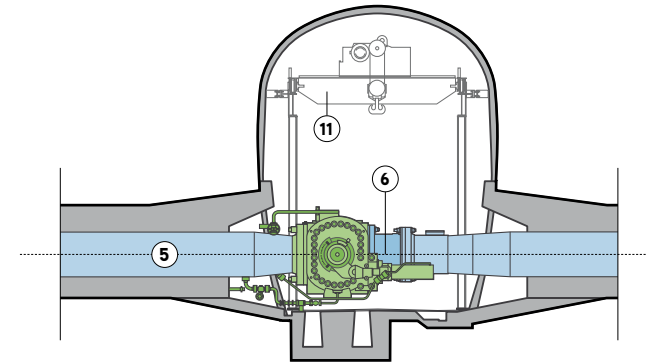

- 1 GATE VALVE WITH BEARINGS
- 2 BODY OF THE VALVE
- 3 COVERS
- 4 BEARING BUSHES
- 5 UPSTREAM PIPE
- 6 DOWNSTREAM REMOVABLE PIPE
- 7 RECONDITIONING JOINT
- 8 SERVICE JOINT
- 9 SERVOENGINE
- 10 SERVOENGINE LEVER
- 11 160 TONS OVERHEAD CRANE

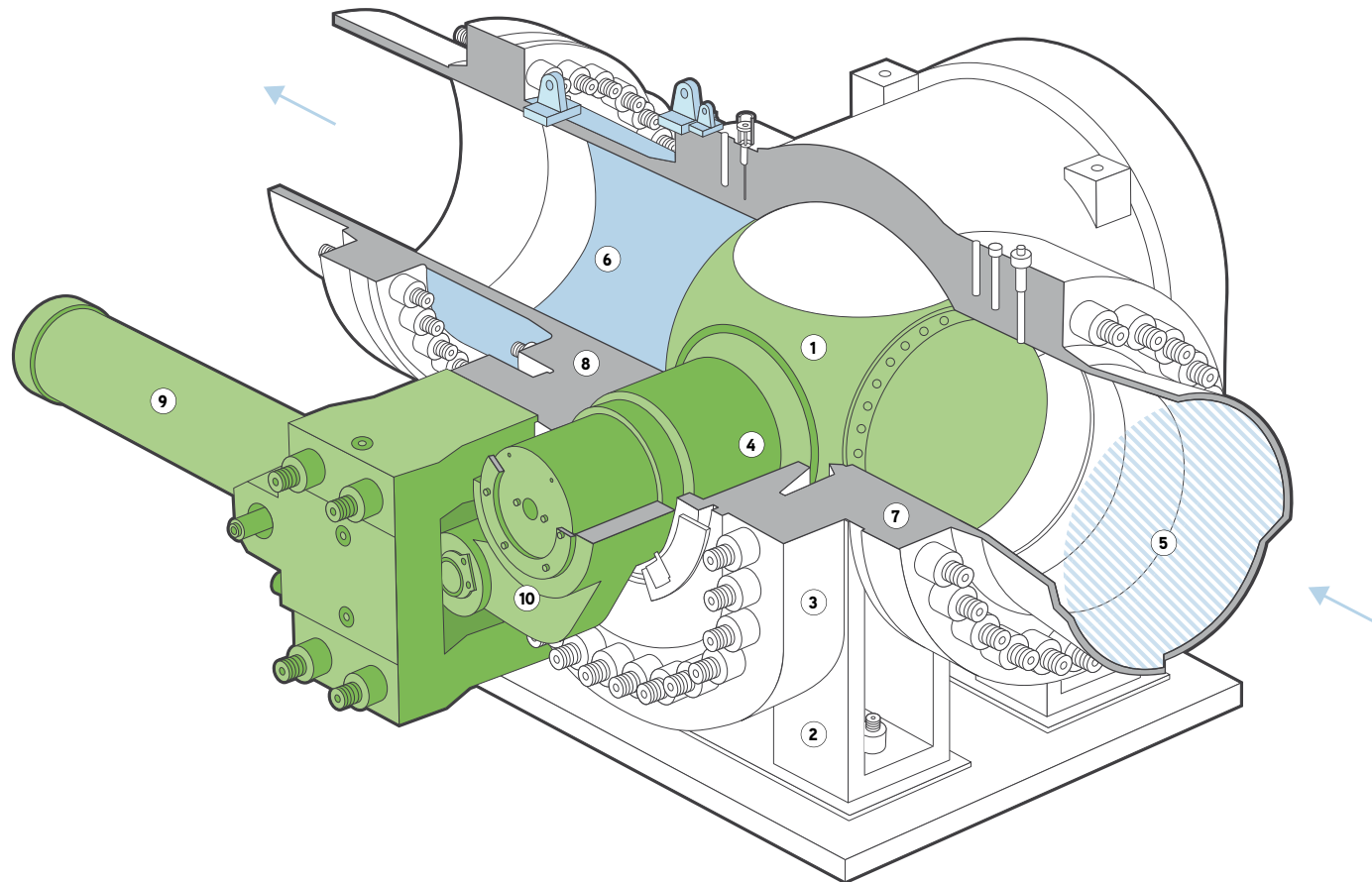

BIEUDRON POWER PLANT

LONGITUDINAL CROSS SECTION

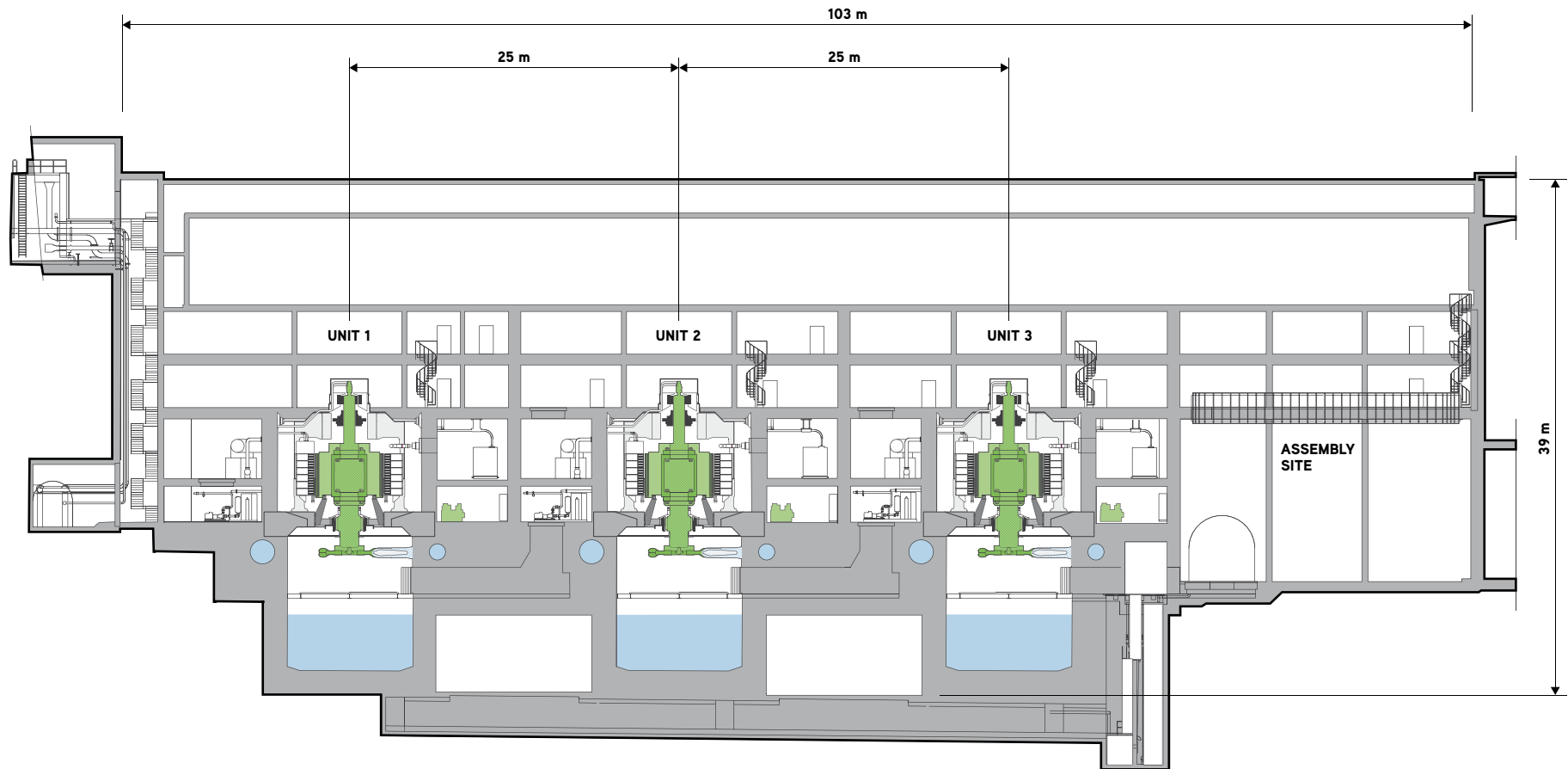

BIEUDRON POWER PLANT

TRANSVERSE CROSS SECTION

- 1 DISTRIBUTOR
- 2 VALVES CHAMBER
- 3 250 TONS OVERHEAD CRANE
- 4 MACHINES ROOM
- 5 TUNNEL FOR LOW AND MEDIUM VOLTAGE CABLES
- 6 LOW WATER TUNNEL
- 7 BAR TUNNEL
- 8 FLAP GATE
- 9 TAILWATER BRANCH
- 10 TRANSFORMER CELLS
- 11 TAILRACE

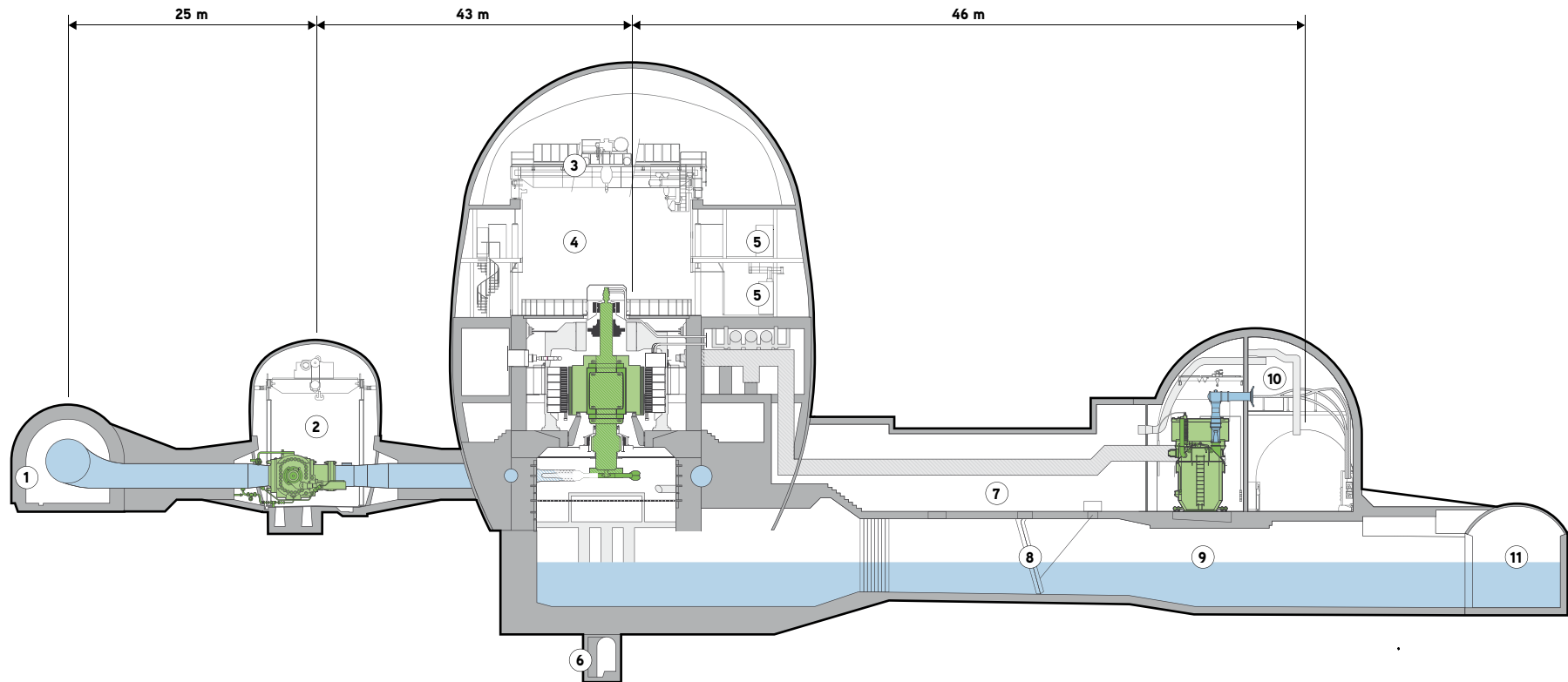

BIEUDRON POWER PLANT TRANSFORMER

- 1 BUSBAR INPUT
- 2 THREE PHASE TRANSFORMER
465 MVA - 21 kV/410 kV
- 3 CABLE-TRANSFORMER SF₆ CONNECTION
- 4 230/410 kV CABLES
- 5 CABLE SUPPORTS
- 6 VENTILATION
- 7 CABLE GALLERY
- 8 CO₂ FIRE PROTECTION
- 9 SMOKE EXTRACTION

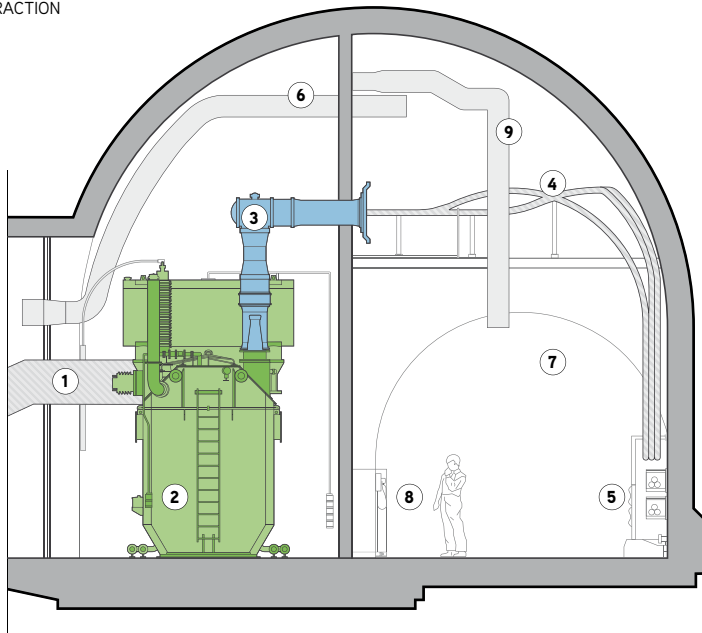

230/410 kV CABLE

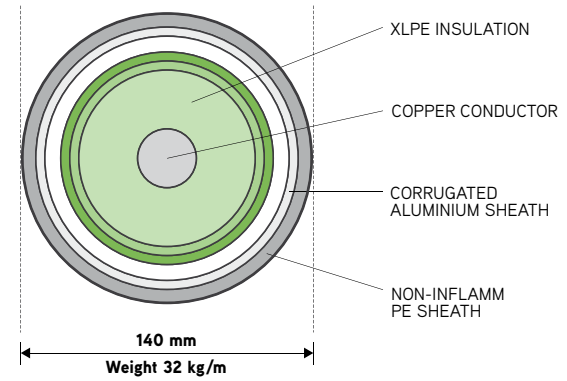

21 kV BUSBAR CROSS SECTION

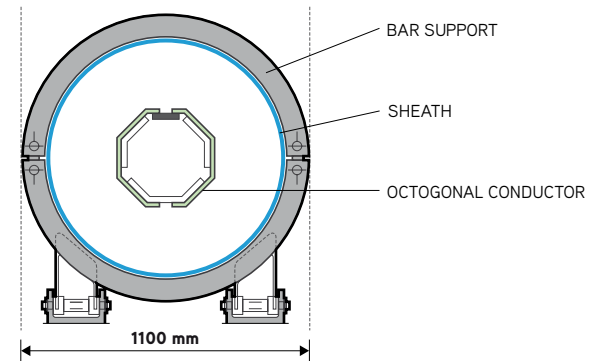

BIEUDRON POWER PLANT

TURBINE-GENERATOR UNIT

COMMAND AND CONTROL SYSTEM

- 1 GENERATOR SHAFT
- 2 EXCITER
- 3 ROTOR - COOLING WATER
- 4 ROTOR
- 5 STATOR
- 6 TURBINE GUIDE BEARING

- 7 PELTON TURBINE
- 8 RACK AND PLATFORM
- 9 INJECTOR
- 10 BUSBARS
- 11 COMBINED TRUST AND BEARING SUPPORT

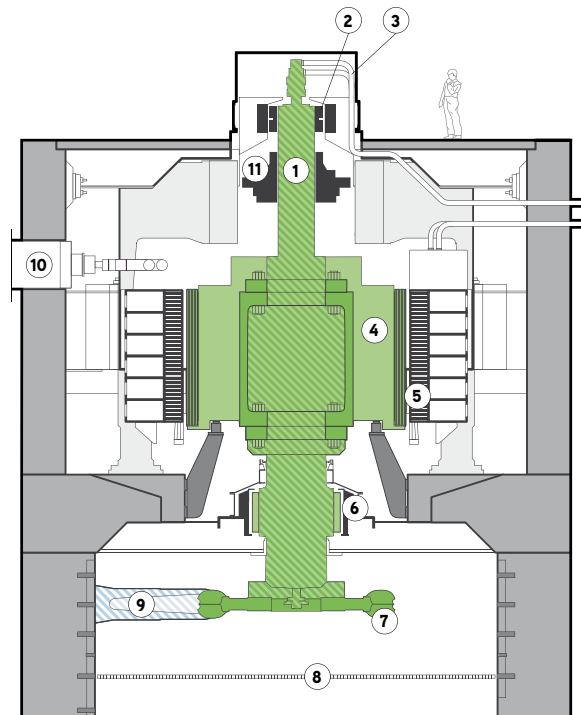

ROLE OF COMMAND AND CONTROL SYSTEM

- Automatically control all components in the power plant, locally or remotely from the Alpiq control centre
- Guarantee maximum safety of individuals and property
- Ensure the optimum availability of production generators

GENERAL SPECIFICATIONS OF THE COMMAND AND CONTROL SYSTEM

Division into decentralised elementary systems each including:

- A direct mode or local service
- An automatic mode, local or remote control
- Control panels
- Redundant automated devices

Number of elementary systems:

- 12 systems for general power plant operations and headgates
- 18 systems for each unit

Total systems across facility:

- 85 CPUs
- approx. 8000 digital inputs
- approx. 8500 digital outputs
- approx. 500 analogue inputs
- approx. 100 analogue outputs



PENSTOCK REHABILITATION WORK



Following the rupture of the Cleuson-Dixence penstock on 12th December 2000, EOS Holding and Grande Dixence SA, the owners of the facility, decided to set up a company in 2003 to plan and manage the rehabilitation works.

Based on consultation and advice from an international panel of experts, Cleuson-Dixence Construction SA has studied several rehabilitation schemes: repair of the current penstock, lining, alternative solutions comprising new deep or semi-deep wells, open air penstocks and combination scenarios.

The solution which appeared to be the most suitable, both in terms of feasibility and high level of safety, was to line the inside of the penstock.

The «old» shielding provides a seal for the new lining against the groundwater and no longer plays a structural role. The total cost of rehabilitation was 365 million CHF.

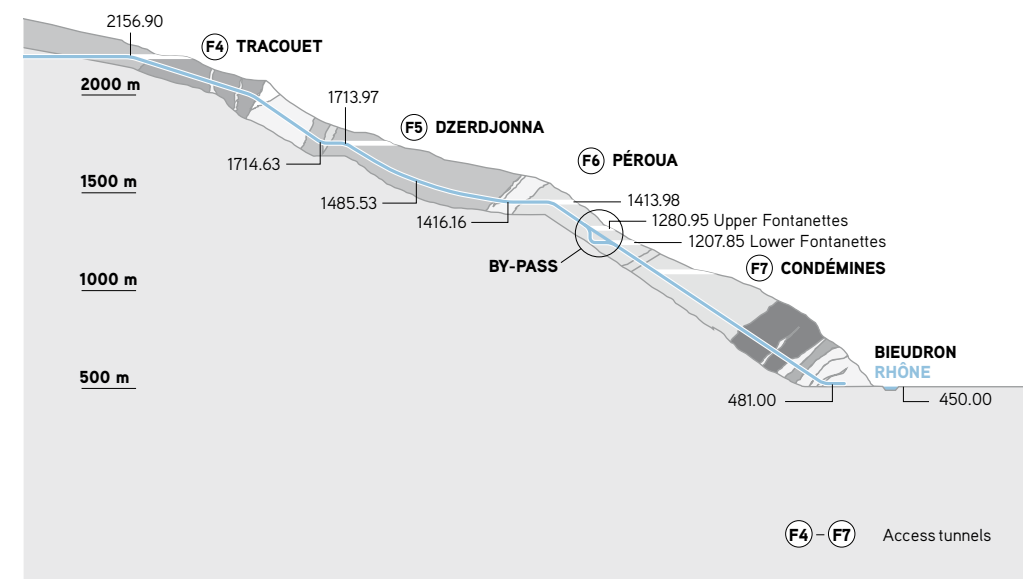

PENSTOCK REHABILITATION WORK

DESCRIPTION OF THE VARIOUS OPERATIONS

LINING: CROSS SECTION

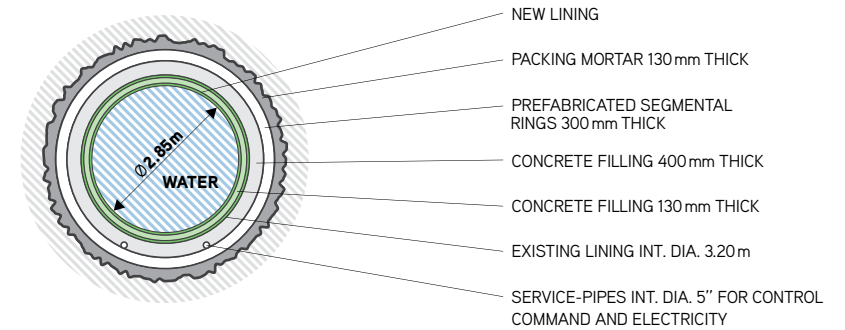

The first work started in 2005. The entire length Tracouet – Dzerdjonna – Péroua – Condémines – Bieudron was rehabilitated. Outside the area affected by the accident, the repair was done by lining the penstock. This means that a new steel tube was inserted inside the existing penstock. In total, 400 pipes, 12'500 tons of steel and 16'400 m of welds were required to create the lining.

In the area where the accident occurred, a workaround solution using a deep by-pass was adopted. The damaged section of the penstock, a length of 117 m, was filled.

Two additional acces tunnels were excavated upstream and downstream of the damage section, to create the access points required for the construction of the bypass. Lining was carried out using steels with a high elastic limit, selected to optimise the quality and performance of the work.

To minimize head loss, the space separating the old penstock from the lining was reduced to the minimum (approximately 10 to 15 cm). This space was filled with concrete.

The commissioning tests for the Cleuson-Dixence facility started in the middle of 2009 and the Bieudron power plant produced its first kilowatt-hours in January 2010. The rebuilding of the Cleuson-Dixence penstock took 4 ½ years, involving 600 people working around the clock, 7 days a week.

BY-PASS: LONGITUDINAL PROFILE

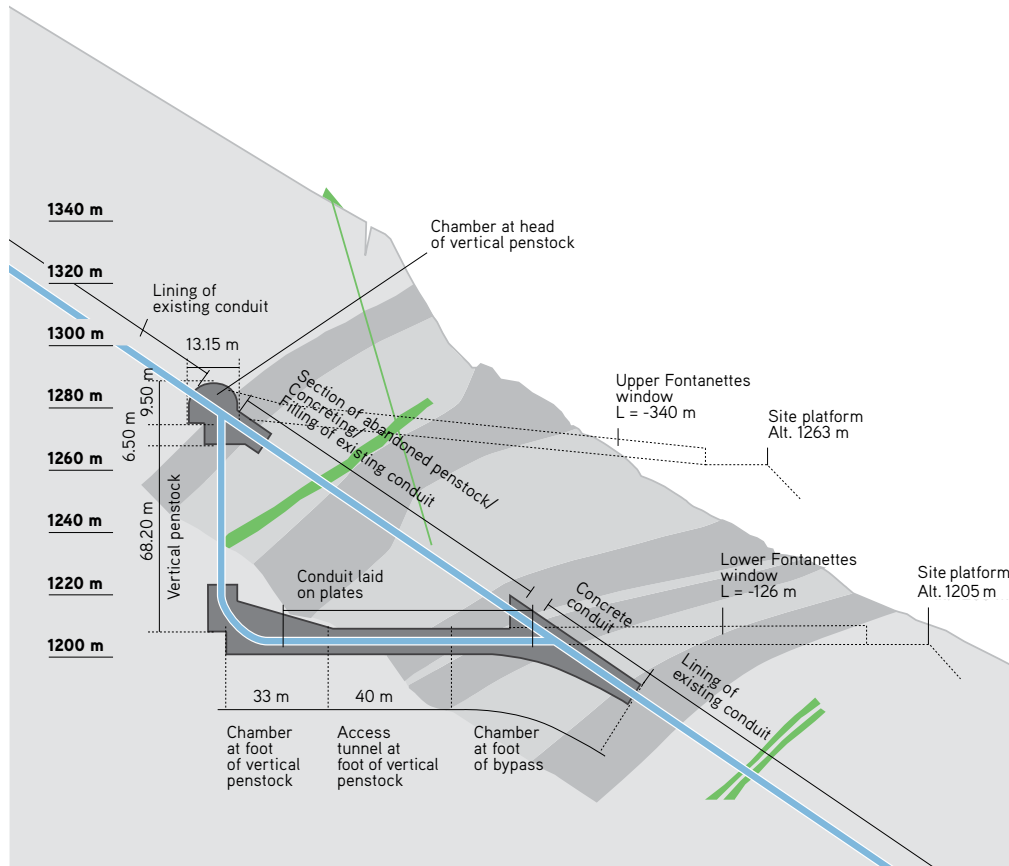



VISITS / CONTACTS

From the power of the mountains to the power of men, experience the story of electricity!

At the Bieudron and Nendaz hydroelectric power plants, buried underneath the mountain, turbines are driven by the water from the Grande Dixence lake.

Come and discover these constructions, which are unique in the world, their history and their features.

Guided visits available, must be prebooked
Open from January to December, working days only
Duration of the visit : 2 hours

CONTACT INFORMATION

www.visit-grande-dixence.ch
visites@grande-dixence.ch
+ 41 27 328 43 43



